



SPECIAL FEATURES

- **Exceptional Spectral Resolution**
 - Patented "Snap-In" gratings
 - Large focal plane
 - Multiple slit locations
 - Rugged Construction
- Extended wavelength range setting
- Temperature Stabilized Base (option)
 - Double Pass optics (option)
- Echelle gratings & prism predisperser (option)

DETAIL SPECIFICATION AND GRATING SELECTION

Focal Length	2-meter, Czerny Turner design Spectrometer with Patented "Snap-In" gratings
Slit Locations	Axial and lateral with optional extra entrance and exit port selection mirrors
f No.	14.1 (17.4 with smaller grating)
Grating Size	120X140 mm (or 110x110mm) - Echelle gratings up to 220 mm wide
Accuracy	0.05 nm (with 1200 G/mm grating)
Reproducibility	±0.005 nm (with 1200 G/mm grating)
Focal Plane	50 mm maximum width, multiply dispersion by the width of your detector for range
Wavelength Range	refer to grating of interest for range, in extended position increase top limit 20%

Grating Groove Density (g/mm)	3600	2400	1800	1200	600	300	150	75
Resolution** (nm)	0.002	0.003	0.004	0.005	0.010	0.020	0.040	0.080
Dispersion (nm/mm)	0.14	0.2	0.26	0.4	0.82	1.66	3.32	6.64
Wavelength Range	185 - 430 nm	185 - 650 nm	185 - 860 nm	185 - 1300 nm	185 - 2600 nm	185 nm - 5.2 um	185 nm - 10.4 um	185 nm - 20.8 um
Available Grating Blazes	Holographic* 240	Holographic* 240 300	Holographic* 400 500	Holographic* 250 300 500 750 1 um	Holographic* 300 500 750 1 um 1.85 um	300 500 750 1 um 3 um 4 um	300 500 750 1.25 um 2.5 um 4 um 6 um 8 um	2 um 3 um 8 um 10 um 12 um

** Spectral resolution typically measured at 313.1 nm

All specifications are for single pass operation.

PM1075-1

HIGH RESOLUTION PERFORMANCE

The McPherson Model 2062DP is the highest resolution diffraction spectrometer commercially available. This unique 2 meter focal length Czerny Turner can be equipped with large gratings (up to 220 mm wide). Grating rotation in excess of 70 degrees is allowed and double pass optics can be installed. These double the dispersion and resolution without influencing the f/no. or aperture ratio.

The graphs below show the actual performance of the McPherson 'DP' or Double Pass systems dispersion doubles. Performance data is based on a system equipped with a 316 g/mm Echelle grating working in 10th diffracted order, rotated to 71.69 degrees and operating at a central wavelength of 600 nm.



McPherson Model 2062 shown with axial and lateral slits, double pass central slit and water channel equipped base (for best thermal stability.)

<i>Data based on theory</i>	Effective Slit Width (mm)	Single Pass Resolution (nm)	Single Pass Resolving Power	Double Pass Resolution (nm)	Double Pass Resolving Power
Simple Geometric slit width	0.010	0.0004	1,445,054	0.0002	2,890,107
Diffraction (220-mm grating)	0.027	0.0011	528,072	0.0006	1,056,146
Aberration (single pass)	0.033	0.0014	439,698	~	~
Aberration (double pass)	0.038	~	~	0.0008	753,325

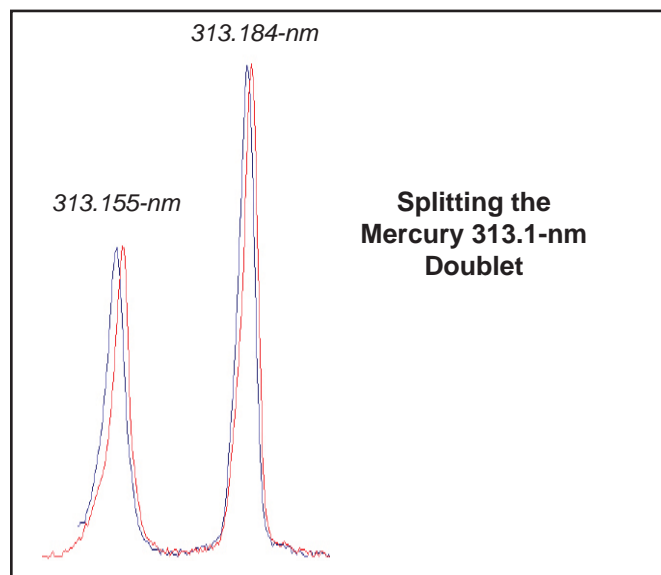
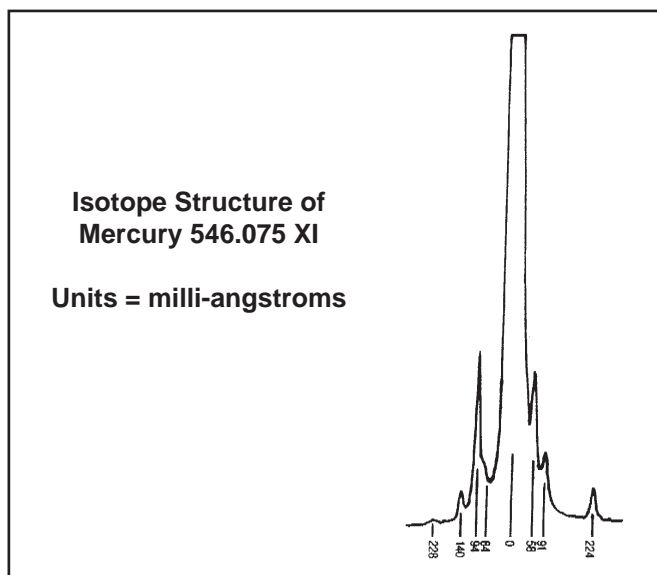

Pm1075-2

DOUBLE PASS OPTICAL LAYOUT

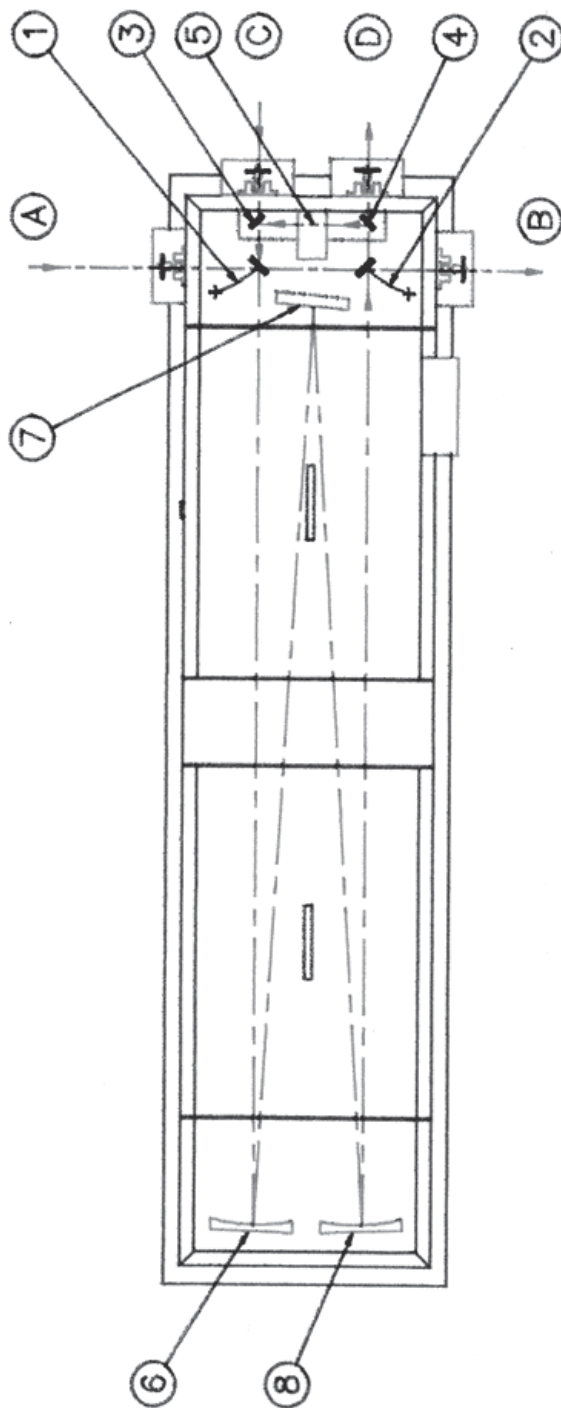

The Double Pass (DP) optical arrangement intercepts and folds the normally exiting beam **D** with mirror **4** and directs it through an intermediate bilaterally adjustable slit **5** and onto mirror **3** to start through the instrument again. Then starts the second pass to collimator **6** from where it is directed at the grating **7**. Energy, upon being dispersed again, reaches the focusing mirror **8** and exits finally through slit at **D**. It should be noted that for double pass, entrance and exit slits **C** and **D** are used. Slits at the lateral positions, **A** and **B** are reserved for single pass applications. Useful beam height in double pass mode is 8 mm, in single pass heights, to 20 mm can be used. Mirrors **1** and **2** (if they have been installed) can be used to select either single or double pass mode of operation.

Exit ports **D** and **B** can be equipped with slits or with other accessories like intensifiers, CCDs or PDAs.

Entrance slits accept our Model 608 prism predisperser for elimination of higher orders, which can be useful when working with echelle gratings.

2-meter focal length, f/14.1

**HIGH RESOLUTION
MODEL 2062 SPECTROMETER**

Dimensions are in inches and are
provided for reference only.

