

## 1m f.l. Soft X-ray and Extreme UV Monochromator

The 248/310 is a 1000 mm focal length Rowland circle grazing incidence vacuum monochromator. It has 0.02 nm fwhm spectral resolution with 1200 g/mm grating. Its precision slits are micrometer adjustable from 0.005 to 0.5 mm. The 248/310 features a chord-length meter and manually operable wavelength drive for years of accurate and reproducible wavelength positioning. The scan controller provides computer/software control. The high performance instrument provides excellent performance from 1 nanometer up to 300 nm in the UV.

Use the 248/310 for XUV, SXR or extreme UV applications. The compact housing is easily adapted to most experiments. We can provide it complete with vacuum pumps, microchannel plates and CCD detectors.

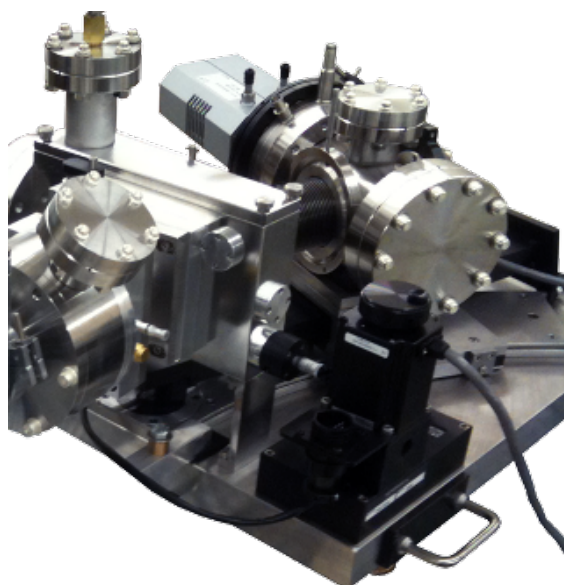

**1 to 310nm range | Direct-CCD, scanning slit, MCP configurations | Large assortment of gratings**

Optical Design	Rowland Circle Grazing Incidence Monochromator
Angle of Incidence	87 degrees standard, 84 to 88 degrees optionally available
Focal Length	1 meter
Acceptance	20 mrad
Wavelength Range	refer to grating of interest for range
Grating Size	20 x 25 mm (single, kinematic grating holder)
Slits	Continuously variable micrometer actuated width 0.01 to 0.5 mm. Settable height.
Vacuum	High vacuum 10E-6 torr standard, UHV optionally available
Focal Plane	40 mm microchannel plate or 25 mm direct detection CCD

### Ordering Information

Part Number: 181-104424 = Model 248/310 Rowland circle grazing incidence monochromator, 1m, 20 mrad, adjustable entrance and exit slits (requires scan controller and software)

**Performance with different gratings**

Groove Density (g/mm)	<b>3600</b>	<b>2400</b>	<b>2160</b>	<b>1800</b>	<b>1200</b>	<b>600</b>	<b>300</b>	<b>150</b>	<b>133.6*</b>
Spectral Resolution <sup>1</sup> (nm, FWHM)	0.006	0.009	0.01	0.012	0.018	0.036	0.07	0.14	0.16
Dispersion (nm/mm)	0.025 - 0.09	0.03 - 0.15	0.03 - 0.15	0.04 - 0.18	0.05 - 0.27	0.08 - 0.34	0.08 - 0.34	0.16 - 0.7	0.4 - 1.6
Wavelength Range <sup>2</sup> 1 nm up to (nm)	10	15	17	20	30	65	130	260	300
Blaze Angle (deg)	Holo	Holo	1	Holo	Holo	Holo	1	2	2
	1	2	3		1	1	2		
					2.3	2			

- \* The 133.6 grating strongly recommended for calibration, setup and alignment
1. Tested in scanning mode at 185 or 312 nanometers with 10 micron wide slits
  2. Gratings work best from 2/3 blaze wavelength to 3/2 blaze wavelength

**Partial Grating selection**

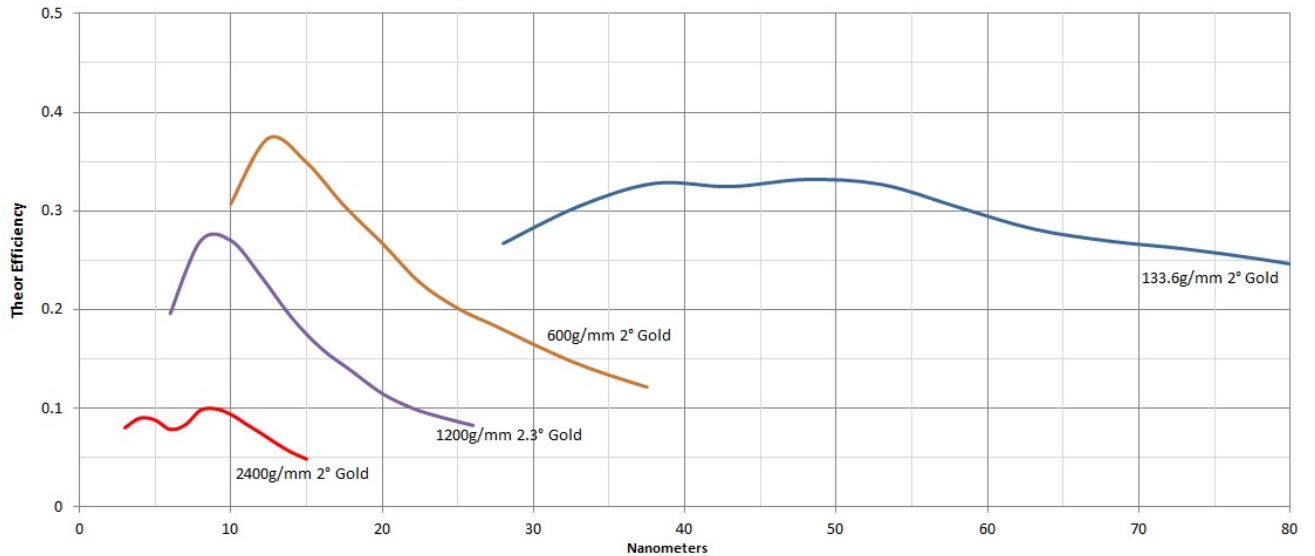

**248/310 Dimensions**

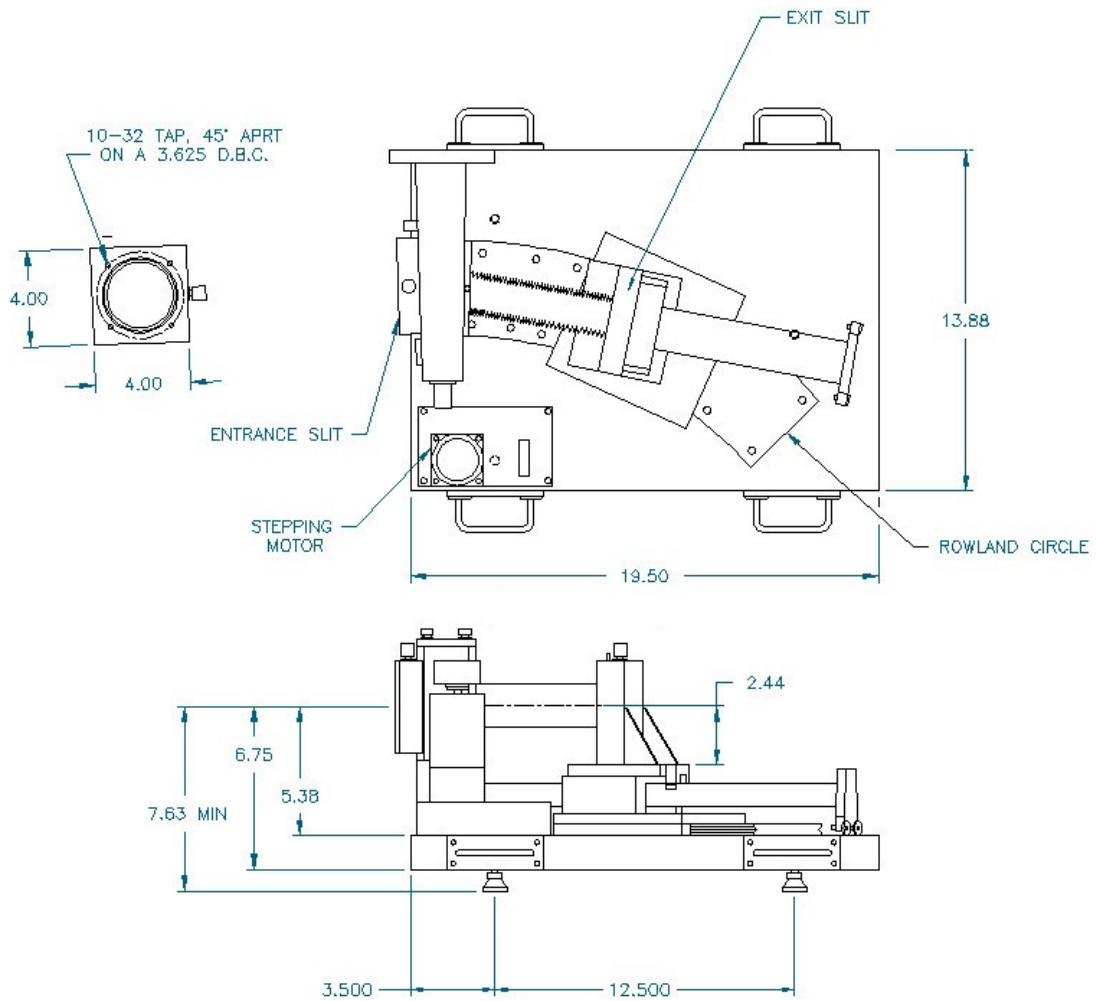

**248/310 Sample Spectrum (HHG experiments)**

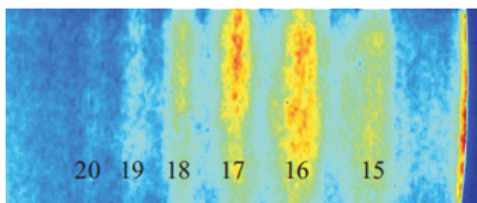

Left: Images of HHG-spectra recorded at different central wavelength positions using the McPherson grazing incidence spectrometer with MCP and Andor CCD (Max-Planck-Institute). Below: HHG scanning mode spectra (Friedrich-Schiller-University)

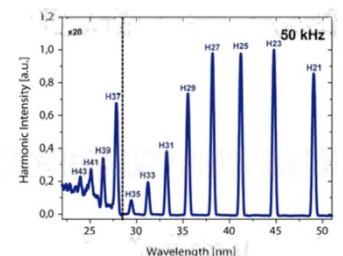
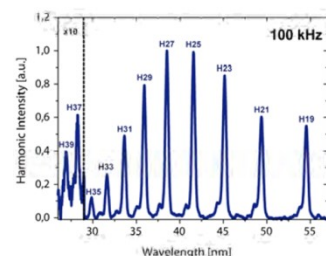
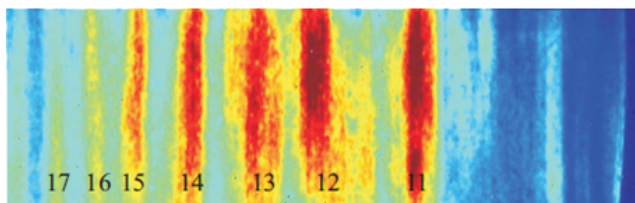

**Instrument Configurations**

**Model 248/310 one meter grazing incidence spectrometer with direct detection CCD** (Andor-Technology DO420BN-995) This instrument is mounted vertically, looking down into the XAPPER light source at Lawrence Livermore National Laboratory. XAPPER is a “Radio-frequency-preionized Xenon Z-pinch source for Extreme Ultraviolet Lithography” used for damage threshold and ablation experiments. Some typical spectra are shown below.

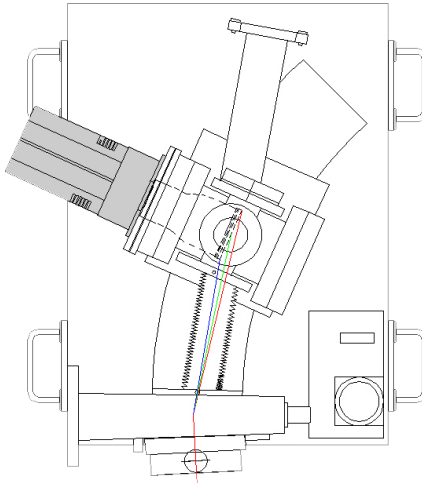
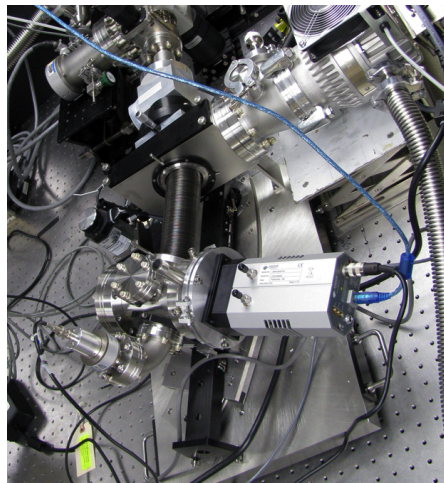
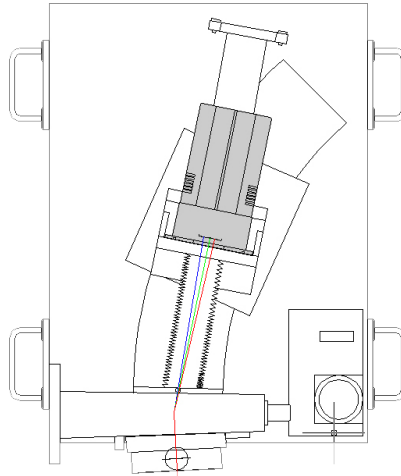

**Model 248/310 one meter grazing incidence spectrometer with microchannel plate intensifier and Andor-Technology DH420A-FO CCD:** The microchannel plate (MCP) mounts tangent to the Rowland circle to intercept best focus across the detector array. In addition to gain, the MCP may be gated and synchronized with signals from the experiment. The MCP is efficiently fiber coupled to the CCD. (UNM)

**Some technical papers with 248/310**

- Photon Diagnostic for the Seeding Experiment at FLASH (Free-electron LASer at DESY, Germany)
- Influence of current prepulse on capillary-discharge extreme-ultraviolet laser
- High-order harmonic generation directly from a filament
- Spatial fingerprint of quantum path interferences in high order harmonic generation
- High harmonics from solid surfaces as a source of ultra-bright XUV radiation for experiments
- A Gigawatt High-Voltage Generator for Coherent Soft X-Ray Generation
- Liquid-jet laser-plasma extreme ultraviolet sources: from droplets to filaments
- Influence of Z-pinch evolution on laser pulse duration at 46.9 nm in Ne-like Ar ions
- The Spectrum of Ne-Like Ar and the 4d-4p Transition of Kr7+ at 45 nm in Capillary Discharge Experiment
- Debris-free soft x-ray generation using a liquid droplet laser-plasma target
- Rep-rated X-ray Damage and Ablation Experiments for IFE and ICF Applications
- Effect of multi-shot X-ray exposures in IFE armor materials