

Snapshot of Deuterium emission. The spectra shows from 121 to the large 159 and 161-nm peaks in the Deuterium spectra. The image data corresponds to the spectral data. Data was collected with the McPherson Model 234/302 vacuum spectrometer and Model 632 MgF2 window Deuterium lamp. Only about 600 of the available 1024-pixels on the wavelength axis are shown. Sensor was 1024 x 256 with 26-um square pixels.

A layout of the dual use Model 234/302 with one exit slit for scanning applications with a PMT and another exit port equipped with a back illuminated CCD.

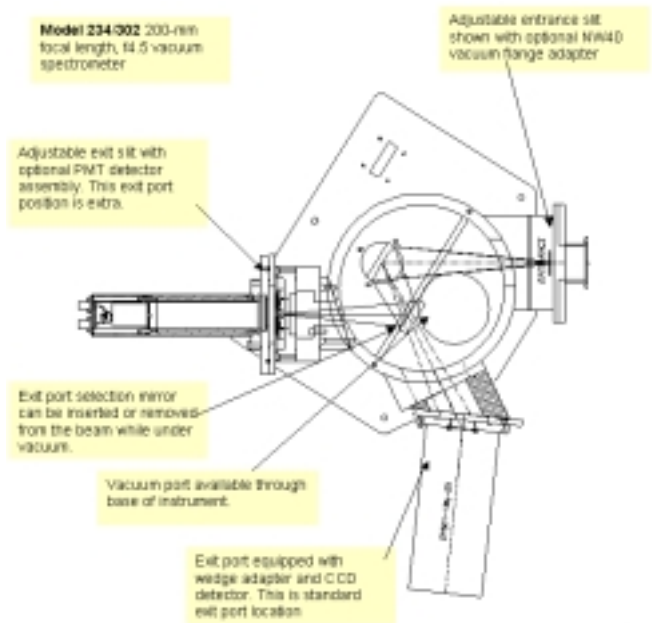

Vacuum Spectrometer for CCD Detectors

McPHERSON MODEL 234/302

Easily reach the Deep Ultraviolet (DUV) and Vacuum Ultraviolet (VUV) wavelength region with this McPherson spectrometer. Access the overall range of 30 to 550-nm with standard, readily available, gratings. Providing dispersion varying from 3.5 to 4-nm about 100-nm can be intercepted in a single acquisition.

Use windowless, back illuminated and uncoated CCD sensors for detection throughout this range. Most CCD sensor packages with 5-mm or less sensor depth adapt to this instrument. CCD detectors provide data with full vertical binning. Alternately, we can (and usually do) provide an in vacuum shutter allowing use of all CCD data acquisition modes.

The vacuum spectrometer can be configured as a dedicated vacuum spectrograph or as a combination, monochromator and spectrograph. If the latter, two exit port are provided with an in vacuum selectable port mirror.

