

**Compact – Rugged –
Lightweight – Low cost**

High throughput (f/4.5)

Type IV concave holographic gratings

Aberration corrected optical system for imaging

Multiple port versions available on request

Spectrometer & Spectrograph operation

The optical design is based on the Seya-Namioka, simple grating rotation changes the output wavelength. To make use of special grating technologies a 64° degree included angle is used. A 1200 g/mm type IV aberration corrected concave grating is used for optimum performance.

The concave grating collects, disperses and focuses energy at the exit focal plane. Type IV correction maintains a fixed focal length to the exit slit, which while not perfect, varies less than the depth of focus of the diffracted image. Compensation for spherical aberration is made by utilizing curved rulings. As the grating rotates to longer wavelengths the image height is compressed maintaining good throughput and imaging qualities. Typically this instrument will have one third the astigmatism of a typical Seya-Namioka design.



Figure 4. Model 234/302, 0.2 meter focal length vacuum scanning spectrometer.

A compact, lightweight design allows users to mount this instrument directly to experimental chambers. By design, the slit assemblies can support the weight of the entire instrument.

Model 234/302 is popular for use in systems due to its compact design, high throughput and resolution. The system shown below combines a MgF₂ windowed deuterium source, an optimization optic, and a collimating chamber.

The arrangement shown is commonly used by industrial quality control in crystal growing, thin film / filter measurement, detector response testing, excitation of phosphorescent materials, etc. Note that use of the collimating chamber restricts use of the system to wavelengths longer than 105 nm due to the additional optical surfaces.

**Model 234/302
part #: 8183-0234-1**

Focal length: 200 mm
Included angle: 64°
f/number: 4.5
Resolution: 0.1 nm***
Dispersion: 3.4 nm/mm**
Accuracy: 0.1 nm
Reproducibility: 0.05 nm
Base vacuum: 1 x 10⁻⁶ torr

* with 1200 G/mm, measured with 10 um slits x 4 mm high.

** Other gratings available, divide resolution and dispersion values by the difference in grating groove densities.

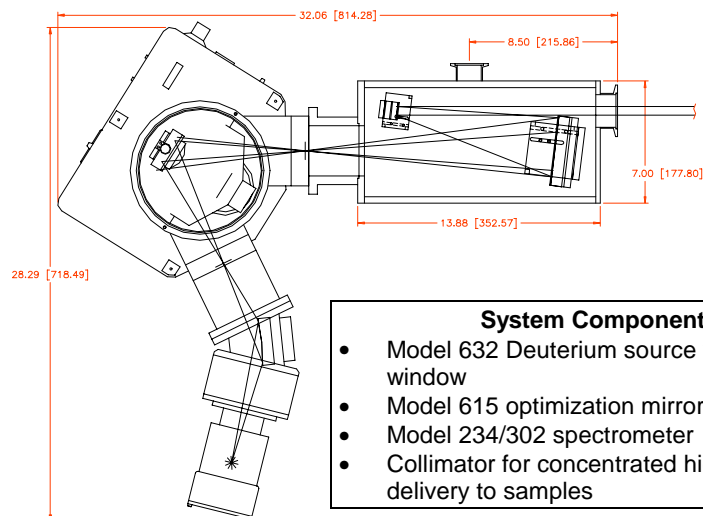

System Components:

- Model 632 Deuterium source with MgF₂ window
- Model 615 optimization mirror
- Model 234/302 spectrometer
- Collimator for concentrated high energy delivery to samples

If a low cost, multiple purpose vacuum ultraviolet spectro-analytical instrument is what your looking for, the Model 234/302 is the answer. It's size (13" x 13" x 10") and low weight (25 pounds) allow this instrument to be fixed to an experiment or to the slit of a larger instrument for use as a predisperser or narrow band variable filter.

Multichannel Operation

The Model 234/302 uses an aberration corrected grating which produces spectra suitably in focus and flat for interception via planar detectors as microchannel plates (MCP) or back illuminated (or scintillated) CCD detectors. Due to the corrected grating the focal plane lies at an angle of about 30° from the normal, placing mechanical restrictions on the detectors which may be employed.

Model 234/302S part #: 8183-0234-S
Focal length: 200 mm Included angle: 64° f/number: 4.5 Resolution:* 0.1 nm* Dispersion:* 3.4 nm/mm Accuracy: 0.1 nm Reproducibility: 0.05 nm Base vacuum: 5 x 10⁻⁷ torr
* with 1200 G/mm, measured with 10 um slits x 4 mm high.

Operating MCP's requires a clean vacuum system capable of consistent 10⁻⁶ torr operation. The Model 234/302S offers a clean, contaminant free finish permitting rapid pump down

and insuring a clean operating environment for the MCP's. Wavelength region accessible with MCP intensified detectors is < 300 Å to the far UV with a

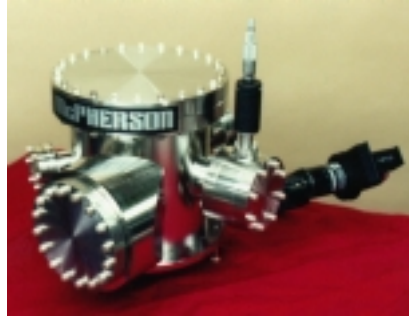

Figure 1. Model 234/302S Spectrograph for use with VUV40RN (TM GEO Corp.) microchannel plate intensifier.

CsI photocathode, of course gated operation to 5 ns or better is available. MCP's intensifiers are described in the detector section.

Double Dispersion & Low Stray Light

The Model 234/302 can be configured as a double additive monochromator.

Mechanically linked versions are built for best tracking between gratings. These units must be specified at time of original purchase. Alternately, existing units can be combined and operated synchronously with independent scanning drives. Wavelength tracking is not as accurate over broad spectral regions because two separate wavelength drives are used (local calibration via computer permits improved tracking in specific areas). Figure 6. Shows a high resolution system providing pure excitation energy to semiconductor samples, where



Figure 6. Dedicated vacuum UV double spectrometer, Model 234/302D

the resulting luminescence is of interest. The system uses a 150 Watt Deuterium source (Model 632MX) an optic for energy collection and f/number matching on both the entrance and exit ports (Model 615).

Model 234/302D part #: 8183-0234-D
Focal length: 200 + 200 mm Included angle: 180° f/number: 4.5 Stray light: 1 part in 10⁻⁸ Resolution:* 0.05 nm* Dispersion:* 1.8 nm/mm Accuracy: 0.1 nm Reproducibility: 0.05 nm Base vacuum: 1 x 10⁻⁶ torr
* with 1200 G/mm, measured with 10 um slits x 4 mm high.

Ultra High Vacuum (UHV) & Contaminant Free

The 234/302U (single or double instruments) is available in clean, all metal sealed versions offering vacuum pressures to 10^{-10} torr.

Residual Gas Analyzer (RGA) certified before shipment these ultra high vacuum compatible units offer the lowest contamination levels in commercial vacuum systems.



Figure 7. Ultra High Vacuum double monochromator, Model 234/302D

The UHV series of instruments are commonly used at synchrotron radiation facilities for measuring beam polarization or gas phase fluorescence emission in the vacuum UV regime. They are also frequently specified when using expensive microchannel plate (MCP) intensified detectors.

<p>Model 234/302 part #: 8183-0234-U</p> <p>Focal length: 200 mm Included angle: 64° f/number: 4.5 Resolution:* 0.1 nm* Dispersion:* 3.4 nm/mm Accuracy: 0.1 nm Reproducibility: 0.05 nm Base vacuum: 1×10^{-10} torr</p> <p>* with 1200 G/mm, measured with 10 um slits x 4 mm high.</p>
--



Figure 8. UHV Model 234/302 produced in OEM quantities as a diagnostic instrument. Applied in monitoring plasma recombination at a fusion reactor in Japan.

Multiple Port Instruments

The Model 234/302 can be supplied with an additional entrance or exit port. A mirror is manually positioned at atmospheric pressure selecting the port to be used. Vacuum selectable mirrors are available permit toggling between two ports while experimenting. Useful on systems where intensity feedback is desired or where two forms of detectors are used, e.g. array detector on

channel detector on another. Instruments must be configured with extra ports at time of initial purchase.

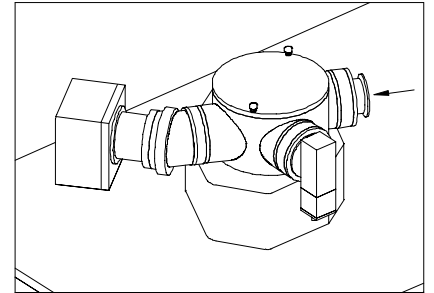

Figure 9. Model 234/302 shown with an additional exit port for an array detector. The primary exit is being used with a photomultiplier tube for highest sensitivity and best resolution.

Grating Selection

The series of gratings for the Model 234/302 range in densities from 300 - 2400 grooves per mm. Efficiency data is shown below for the 1200 G/mm Vacuum UV (*most popular*) and Extreme UV blaze versions.

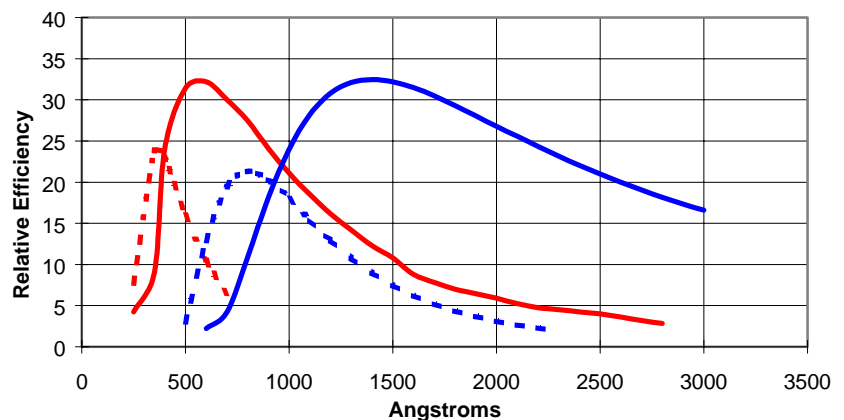

Figure 5, Typical grating efficiencies for the Vacuum UV blaze grating used in the Model 234/302 series, the Extreme UV version shifts the blaze to shorter wavelengths. Dashed lines indicate predicted second order response.

one port and scanning single